

S5000 TECHNICAL BULLETIN

Date	11/10/2021
Topic	Castor Measurement Procedure
Priority	Information

PROBLEM:

To measure the castor angle.

SOLUTION:

The castor angle is the angle, in side-view, between the steering and the vertical axis. It is considered positive when the steering axis is inclined rearwards. You can check the castor angle in the same way at the front and the rear suspension.

The castor angle can be checked as following:

Measure the angle of the steering arm plane for the front (or the wishbone mount plane for the rear) to the reference plane of the car – this is your Measured Castor Angle (MCA). Positive when inclined down to front and negative inclined down to rear (Figure 1).

Calculate the True Castor Angle (TCA) as following:

	Rear Castor Angle	Front Castor Angle
True Castor Angle (TCA)	$= 17.58^{\circ} + \text{MCA}$	$= 7.69^{\circ} - \text{MCA}$
Base Settings		5.1°

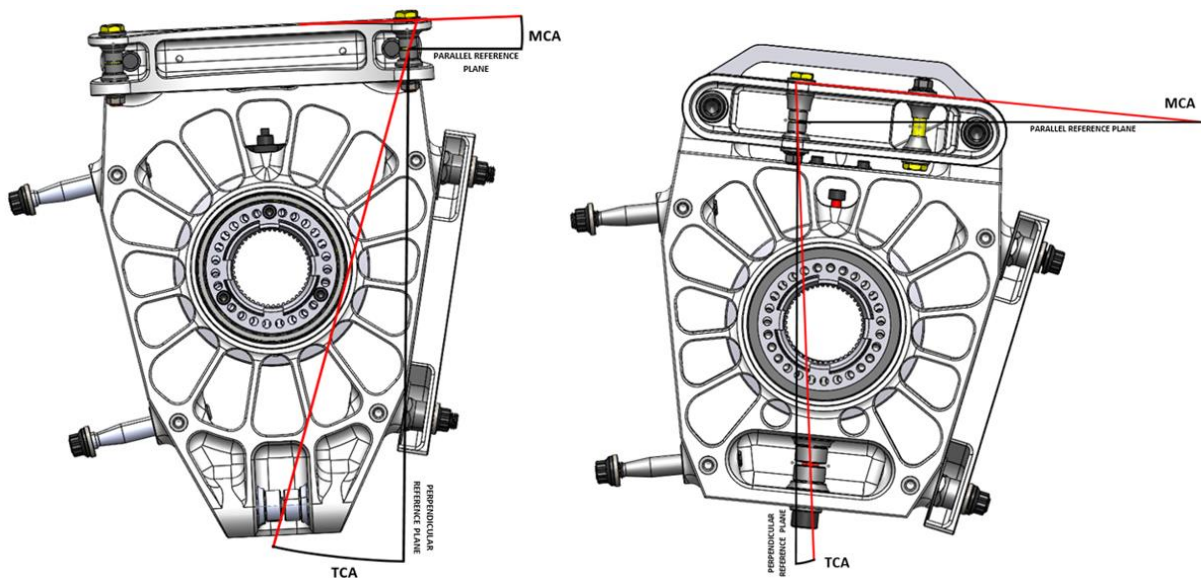

FIGURE 1. CASTOR ANGLE MEASUREMENT

The Castor Angle influences the Castor Offset/Mechanical Trail and therefore the force to turn the wheel. Castor Offset is along the ground plane while the Mechanical Trail is perpendicular to the steering axis.

This information will be added to the S5000 User Guide V03.

Any questions please contact s5000@grmotorsport.com.au